

| | | | | |
|---|----------------|---|----------------|---|
|    | GRUPO | FABRICANTE | MODELO |  |
| | PALA CARGADORA |  | SCOOPTRAM ST14 | |



Motor

| | |
|--------------|-----------------|
| Motor Diésel | Cummins QSM11 |
| Potencia | 250 kW (335 hp) |
| Par máximo | 1674 Nm |

Dimensiones

| | |
|--------------------|----------------|
| Longitud | 10825 mm |
| Anchura | 2800 mm |
| Altura | 2550 mm |
| Galería de trabajo | 5000 x 5000 mm |

Pesos

| | |
|-----------------|----------|
| Peso de trabajo | 39000 kg |
| Peso cargada | 53000 kg |

Capacidades

| | |
|--------------------|--------------------|
| Capacidad de carga | 14000 kg |
| Volumen de cazo | 5,5 m ³ |
| Sistema de cazo | Cuchillas |

Equipamiento

| | |
|------------|-----------|
| Neumáticos | 26,5 x 25 |
|------------|-----------|

Sistema Control

| | |
|----------------|----|
| Control Remoto | No |
|----------------|----|

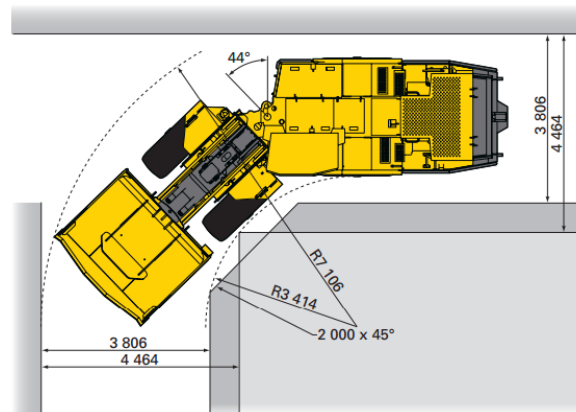
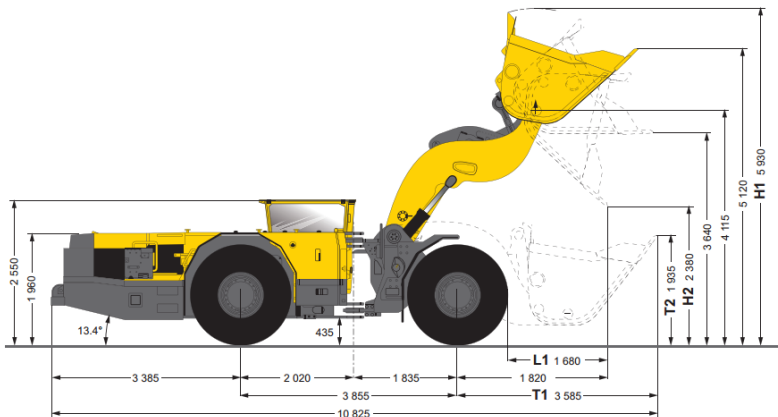

BUCKET DATA

| | |
|---|------------|
| Volume, nominal heaped (m3) | 5.4 |
| Maximum material density (t/m3) | 2.6 |
| Width, bucket (mm) | W 2 800 |
| Tramming position: Axle centerline to bucket lip (mm) | T1 3 480 |
| Tramming position: Ground to bucket tip (mm) | T2 1 785 |
| Truck loading reach: (mm) | L1 1 680 |
| Raised position: Back height, max. (mm) | H1 5 930 |
| Raised position: Bucket tip, height (mm) | H2 2 500 |